

DATA SHEET

2094-MM

GATE DRIVE TRANSFORMER

FEATURES:

PIN THRU HOLE

ELECTRICAL PARAMETERS:

**3750 VOLT ISOLATION
PRIMARY TO SECONDARIES**

**10:10:10 TURNS RATIO
OTHER RATIOS OPTIONAL**

TEMPERATURE RANGE -40 TO 155° C

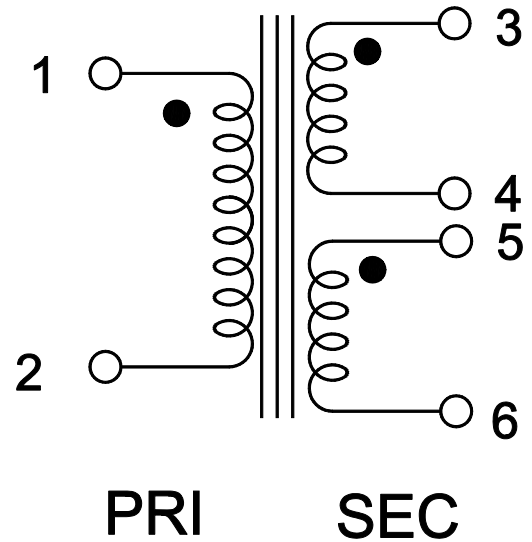
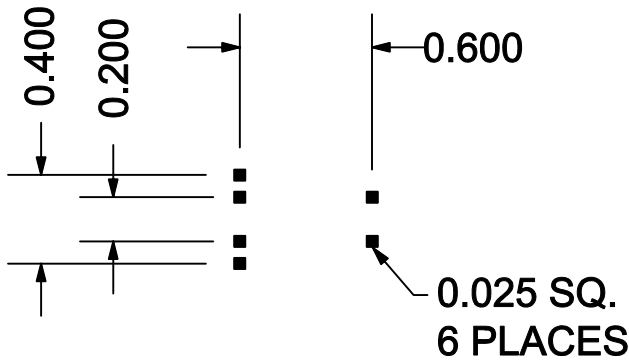
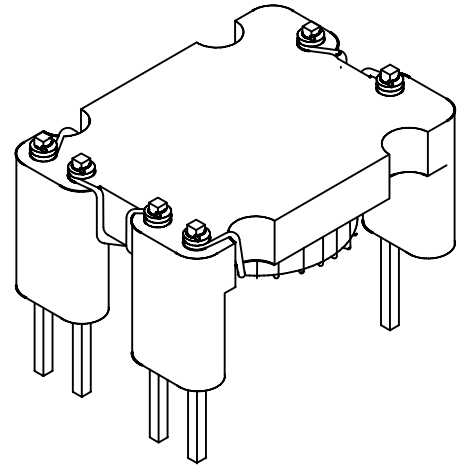

MODEL NAME: Gate Drive Transformer	
SPECIFICATION: PIN THRU HOLE 3750V ISOLATION	
PACKAGING:	
MATERIAL: 40% GLASS FILLED PHENOLIC	
PAGE: 1 of 1	UNITS: INCHES
TOLERANCE: ±.01 / ±.005 / ±1°	
U.L. REC.: 94V-0	
SIGNATURE:	
REVISION DATE:	

GB INTERNATIONAL
 1408 AIRPORT ROAD
 ENDICOTT N.Y. 13760
 PHONE:(607)785-0938
 FAX :(607)785-1109
 E-MAIL :GBI@gbint.com

